

**SINYUAN ZM**  
星源卓镁

# Magnesium-Cast light

NINGBO SINYUAN ZM TECHNOLOGY Co., Ltd.

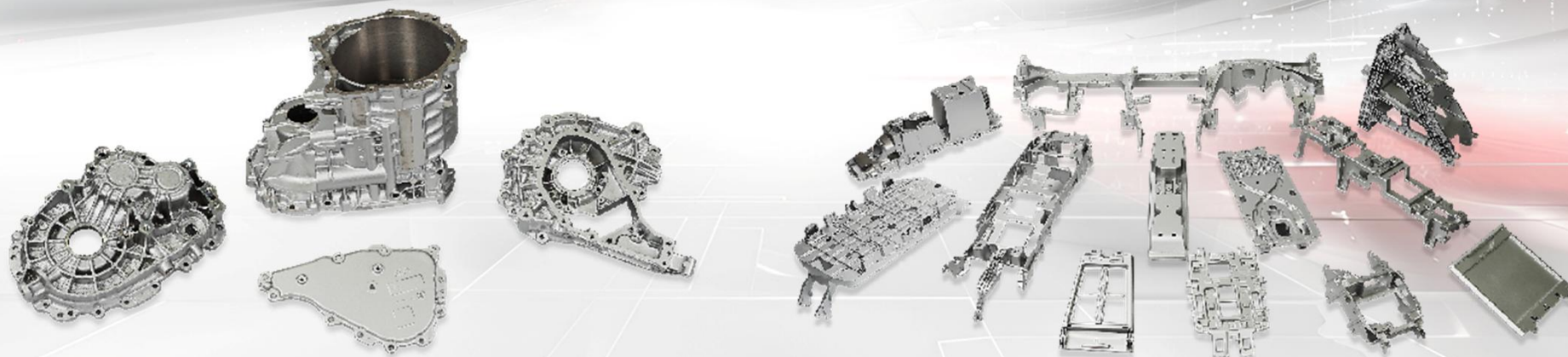

Stock code: 301398

## 20 years focus on lightweight solutions

Singyuan ZM was established in 2003, specializing in the production and sales of aluminum alloy and magnesium alloy die castings. The service covers product design, tooling manufacturing, high-pressure die-casting and thixomolding, CNC machining, surface treatment and assembly, etc. The company is committed to the lightweight application and promotion of aluminum/magnesium alloy castings in automotive electronics, seats, center console, instrument panel, transmission and steering system, and provides more customers with high-quality lightweight solutions.



**>12,000 m<sup>2</sup>**  
Existing Tooling Plant

**>50,000 m<sup>2</sup>**  
Existing Production Plant

**>600 +**  
Employee



**>200 Set**  
Tooling Capa.

**>5000 Ton**  
Production Capa.

**>1000** Ten thousand  
pcs  
CNC Capa.



**50 +**  
R&D employee

**45 +**  
QC employee

**2**  
NA location employee

## #3 Plant planning

Site: Ningbo, China

Area

140,000 m<sup>2</sup>

Time of going into  
production

2025-2026

### Main production line/capacity planning

- 60 Foundry cells with both HPDC and Thixomolding facilities
- 600 CNC machining cells, 3 high-pressure washing lines and 5 wet painting lines
- Covering the entire process from casting to surface treatment



## #4 Plant planning

 Site: Rayong, Thailand

Area

30,000 m<sup>2</sup>

Time of going into  
production

May, 2026

### Main production line/capacity planning

- 10 Foundry cells with both HPDC and Thixomolding facilities and 50 CNC machining cells
- 1 high-cleanliness washing line and dust-free room, and 2 wet painting lines
- Covering the entire process from casting to surface treatment



# Global Footprint

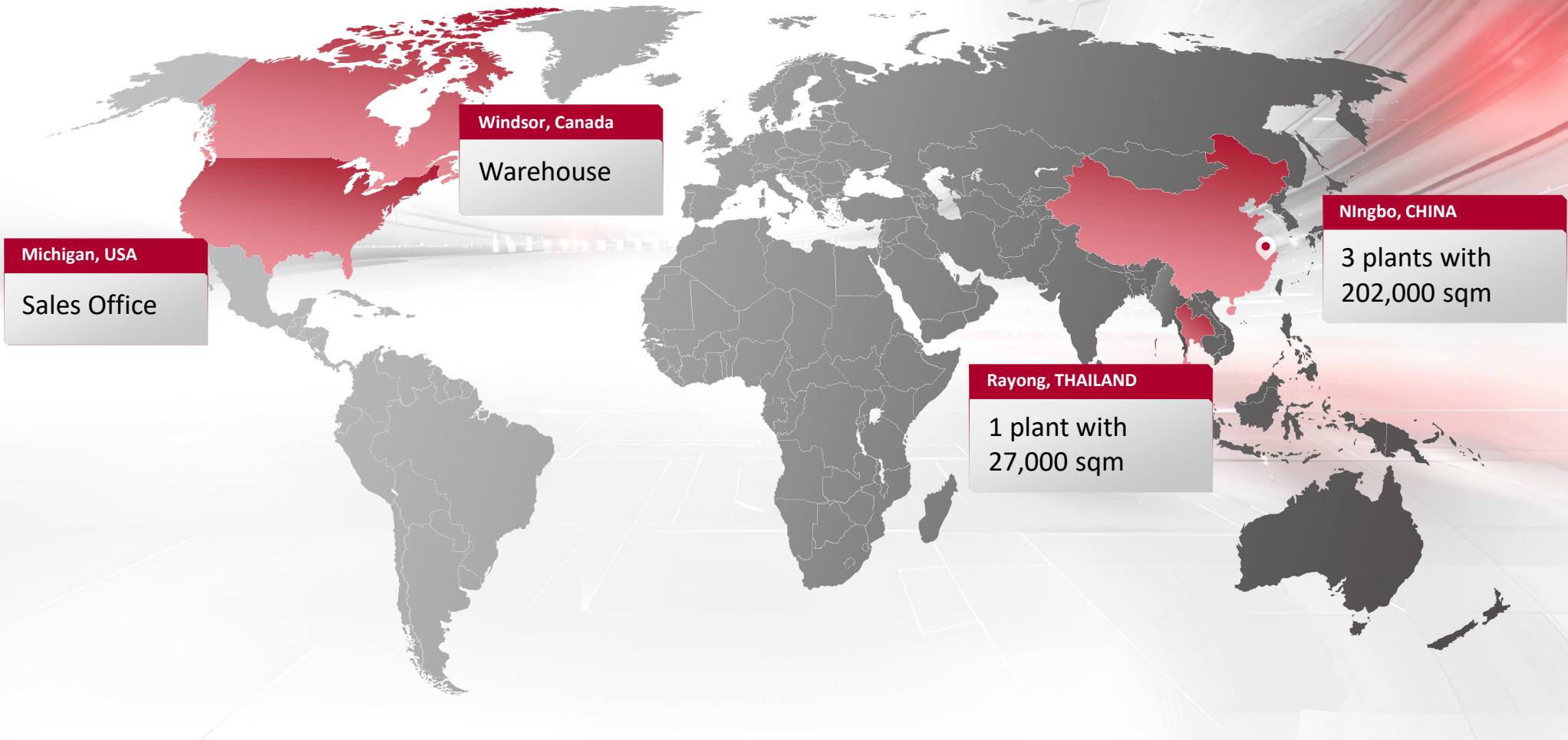

## Revenue Performance and Forecast

With magnesium alloy pricing decline contributed by the magnesium ore's supply chain reformation, EV OEMs pursuing lighter parts, and Sinyuan ZM's processing ability continues to improve, the company's revenue is expected to experience a surge in the coming years.

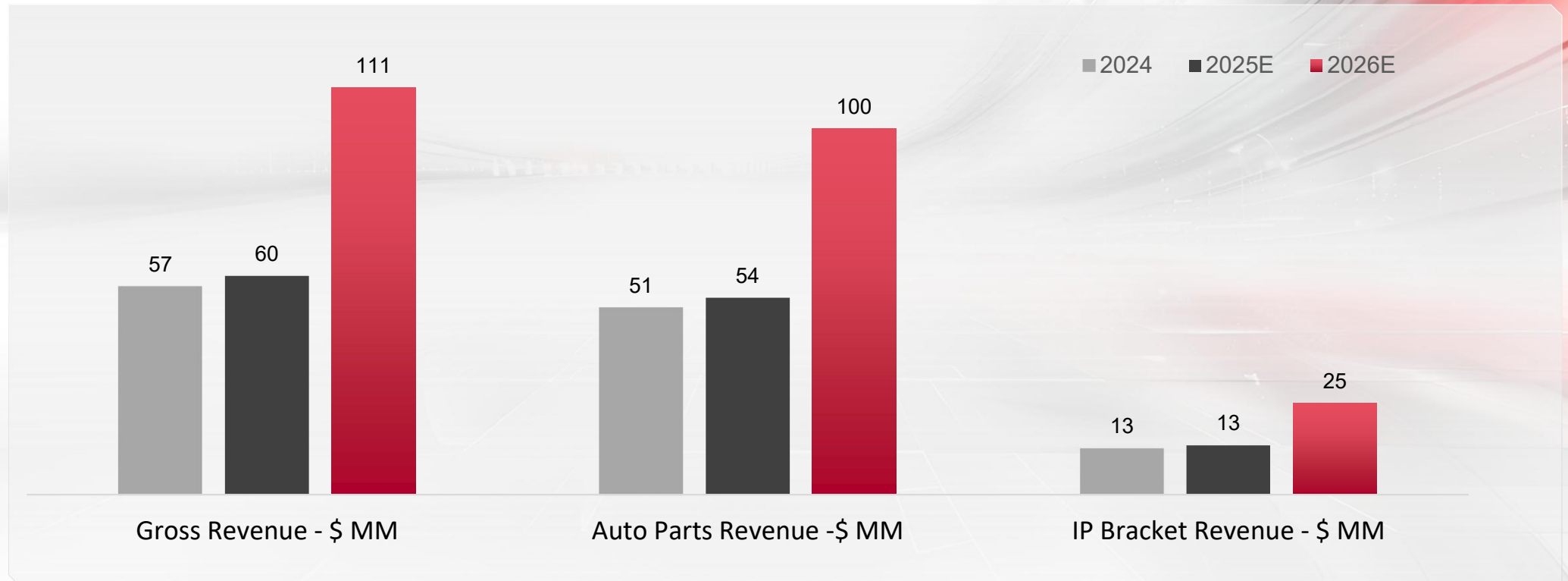

## Strive forward **25 years** Sinyuan ZM to start again

The year 1997

Die casting tooling  
business

The year 2008

Production and  
sales of die-cast  
aluminum alloy  
Step into  
automotive industry

The year 2013

Focusing on  
magnesium, serve for  
headlamp and  
armrest

The year 2018

Initiating IPO,  
expanding  
magnesium supply  
chain to console, CCB,  
transmission case.

The year 2022

IPO successful,  
keeping expanding  
magnesium  
application into bigger  
automotive parts

## Many honors to create excellent quality

### EV Motor

- ▶ International Magnesium Association 2024 Outstanding Magnesium Alloy Automotive Casting Award
- ▶ National high-tech enterprises
- ▶ National specialized giant enterprise
- ▶ National key mold enterprise
- ▶ Council member of the Die Casting Association
- ▶ Member of China Nonferrous Metals Industry Association Magnesium Branch
- ▶ Ningbo enterprise engineering technology center
- ▶ To draft national industry standards for non-ferrous metals
- ▶ Zhejiang high-tech enterprise research and development center qualification



# Leading Through Innovation: Robust IP and Cutting-Edge R&D

Utility model patent

38

Invention patent

10

- Technology and innovation are the core driving forces for the continuous development of Sinyuan ZM
- We provide customers with market competitive product concepts
- We have never stopped exploring new technologies and have always been at the forefront of the industry



# Application of aluminum/ magnesium alloy products in vehicle

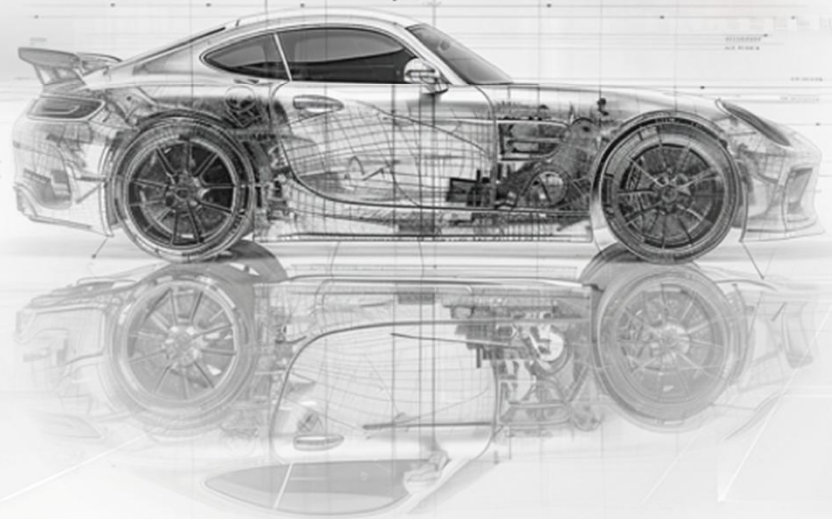

Display  
screen

EV Motor

Console

Instrument  
panel

Armrest

Seat

Door

Headlamp

Front-end  
frame

Tire bracket

Steering  
wheel

Steering  
column

# Customers of the company's main products

## Motor/drive system



## Interior/body structure



## Automotive electronics



# Terminal automotive brand application

## Headlamp



## Motor/drive system



## Interior/body structure



## Automatic drive



## Automotive electronics



# Top Client Ranking

Client-per OEM Customer	Revenue - \$MM	% of Revenue
SAIC Motor Corporation	14.1	24%
Zhejiang Geely Holding Group	7.0	12%
Volkswagen	6.7	11%
General Motor	5.3	9%
Nissan	3.3	6%

Client-per Direct Customer	Revenue - \$MM	% of Revenue
Yanfeng	10.5	18%
CarUX Technology Taiwan	7.3	12%
Viridi E-Mobility Technology	3.5	6%
Grammer Vehicle Interiors	2.9	5%
Aptiv Services	2.7	5%

# One-Stop Service, Self-built factories

## · Design

Seasoned engineers and tooling engineers assist customers in optimizing and improving product design issues

## · Tooling

Capable of self-made tooling fixture and inspection

## · HPDC

Equipped with HPDC large-tonnage machines and mass production of EV Motor

## · CNC

Complete vertical and horizontal machining centers

## · Surface treatment

New automated wet painting and powder coating production line

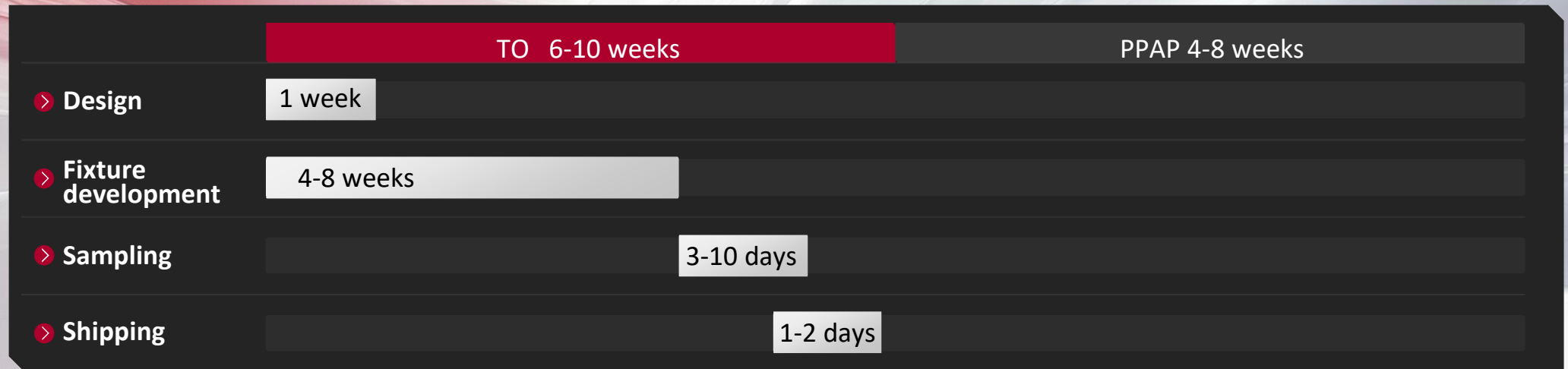

# R&D Design— Customized Design to Meet Customer needs

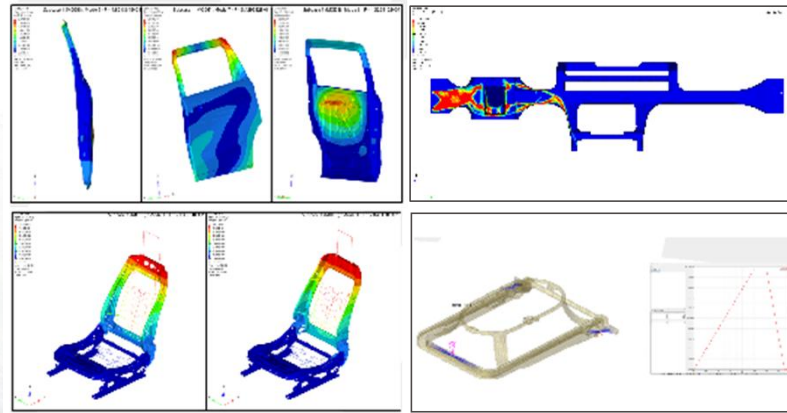

CAE simulation and optimization

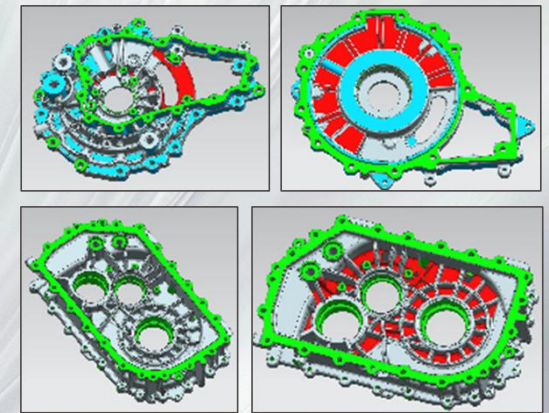

Product structure optimization design

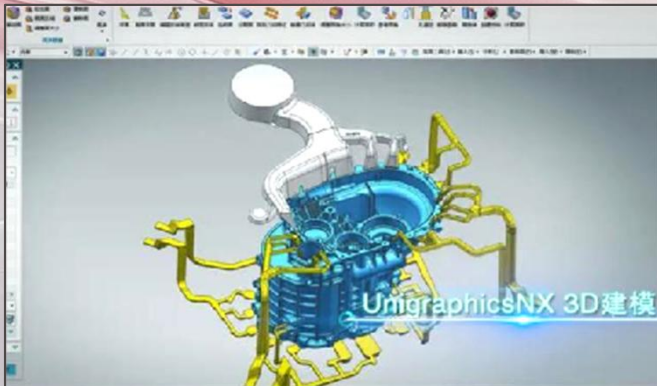

Product 3D modeling

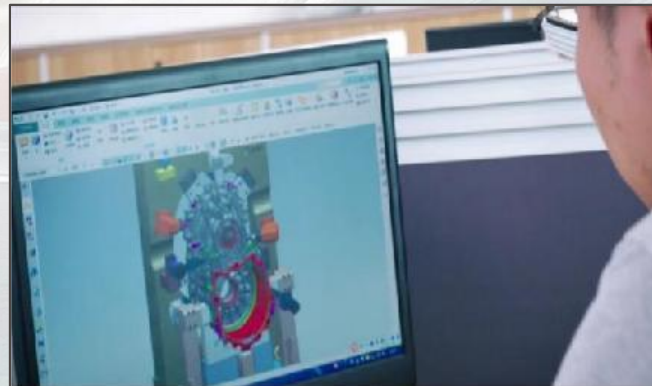

Self designed tooling, fixture and inspection



MAGMA Model Flow Analysis

# Tooling Manufacturing—High-precision and Advanced Equipment, Throughout Tooling Manufacturing and Inspection

10,000 square meters of large-scale modern tooling workshop, with an annual output 200 sets of fixture and tooling maintenance service capacity, forming a solid backing for production.

Facility	Brand	Quantity
High speed CNC	DMG MAKINO	3
Deep hole driller	WIM	1
General CNC	Kafo	8
Wire cutting	SSG	6
EDM	DAEHAN	6

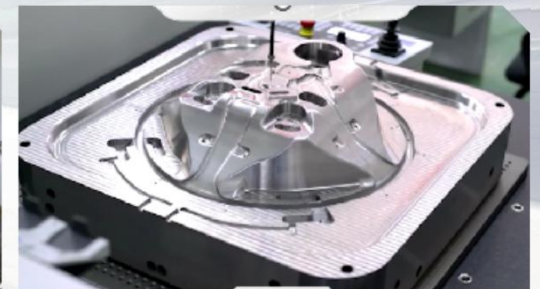
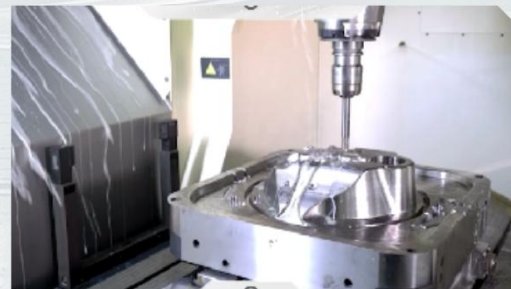

## HPDC—Various Tonnages HPDC Equipment

Facility	Brand	Quantity
HPDC 300T	YIZUMI	3
HPDC 400T	YIZUMI	4
HPDC 500T	YIZUMI	4
HPDC 650T	YIZUMI/HAITIAN	2
HPDC 800T	YIZUMI	4
HPDC 1000T	YIZUMI	2
HPDC 1250T	YIZUMI	1
HPDC 1650T	YIZUMI	1
HPDC 2000T	HPM	1
HPDC 2500T	YIZUMI	1
HPDC 3000T	YIZUMI	1
HPDC 4500T	YIZUMI	1

Equipped with 25 advanced HPDC machines ranging from a minimum of 300T to a maximum of 4500T, we shall meet the differentiated demands of various types of products and cope with production capacity risks.



# Thixomolding – a comprehensive set of Thixomolding machines, including the worlds' largest

Facility	Brand	Quantity
Thixomolding 650T	YIZUMI/JSW	4
Thixomolding 850T	JSW	2
Thixomolding 950T	YIZUMI	4
Thixomolding 1500T	YIZUMI/HAITIAN	4
Thixomolding 2000T	YIZUMI	4
Thixomolding 3200T	YIZUMI	4
Thixomolding 6600T	YIZUMI	1

"Thixomolding technology adopts an integrated molding method that combines die casting and injection molding processes into one. The molds and molding materials are similar to the die casting process, while the process workflow is close to injection molding."

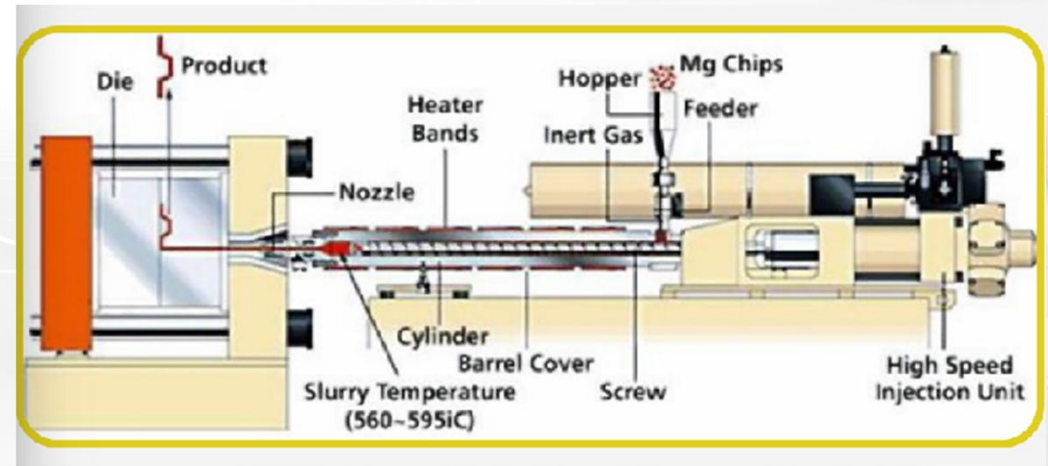

# CNC—Multi-axis Machining Centers, Casting Precision Products

Facility	Brand	Quantity
4-axis	Mazak/Brother/ Fanuc/Other	250
5-axis	Mazak/Brother/ Makino	24
Horizontal machining	Brother/Makino	87

We have currently over 350 CNC machining centers of various types, with an annual CNC machining capacity of 15 million products. Equipped with 5-axis and horizontal machining centers, it can meet the requirements of complex and high-precision products.

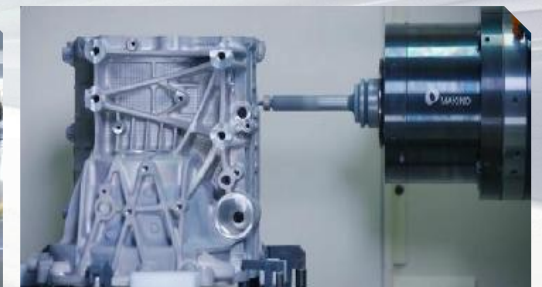
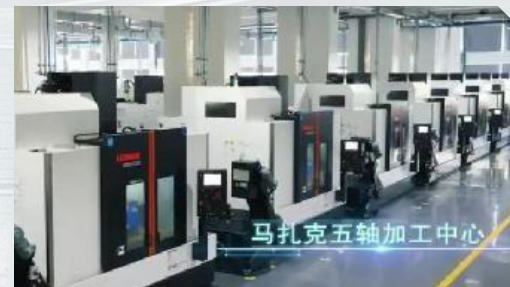

# Surface Treatment— Class 100,000 Cleanroom Level Production Workshop and Class 10,000 Cleanroom Level Spray Booth, High Quality of Surface Treatment

We provides comprehensive surface treatment solutions, including passivation, e-coating, wet painting and powder coating. It has a Class 100,000 Cleanroom level dust-free workshop equipped with advanced robot automatic spraying equipment to meet customer demands quickly and with high quality

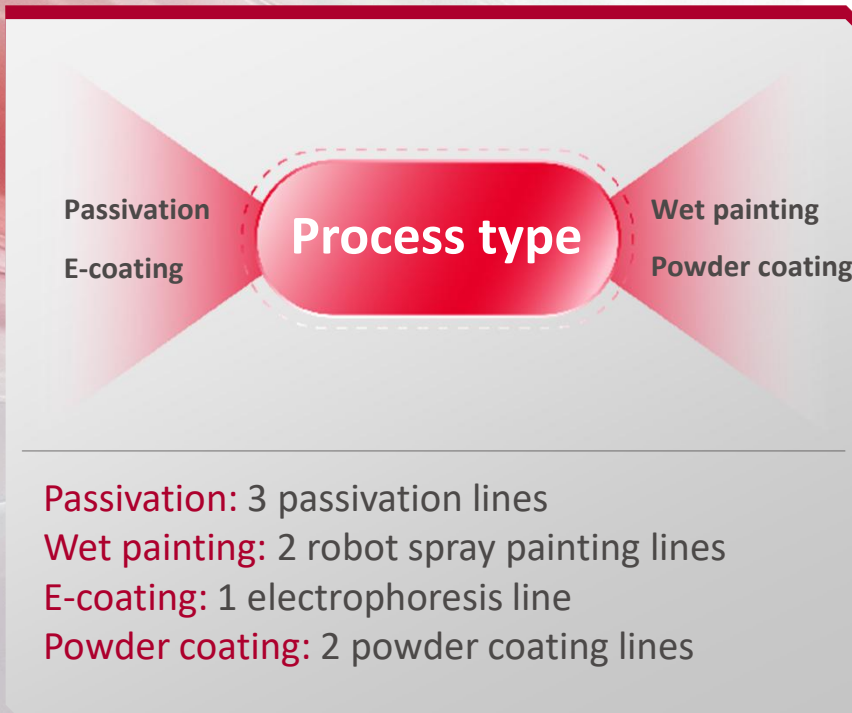

# Quality Control—Complete Software and Hardware, Full Process Control

Facility	Brand	Quantity
CMM	Zeiss	17
CT	Aoying	1
X-ray	Dandong Huari	2
Tensile testing machine	Jinan Kehui	1
Electronic extensometer	Steel Research	1
3D scanner	FARO	1
Digital image measuring machine	Ningbo Xinyue	1
Leeb hardness tester	Beijing Meitai	1
Brinell hardness tester	Huayin	1
Rockwell hardness tester	Shandong Huayin	1
Salt spray test machine	Shanghai Aocheng	2
Profiler	Shaanxi Weier	1
Automatic cleanliness system	Leitz	1
roughness tester	Will gauge	2
metallographic microscope	Keyence, Japan	1
Spectrophotometer	KONICA	1
Small colorimeter	KONICA	1

To support the principle of quality first, we have invested in advanced laboratory equipments to control raw materials and all production processes.



# Full set of Automated Capabilities

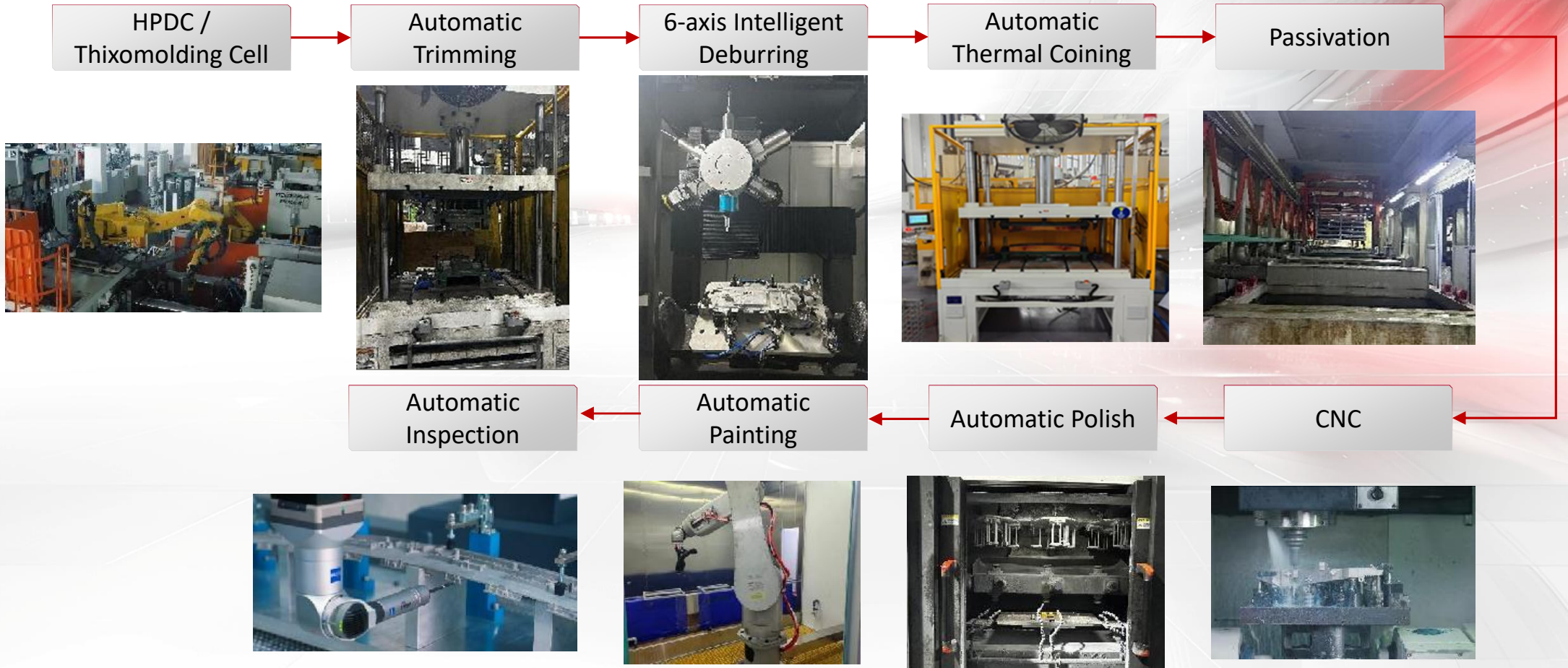

▮ Magnesium-Cast light

SINYUANZM  
星源卓镁

## IP Bracket

Material: AZ91D

Part length: 360mm

Screen size: 15.4-inch

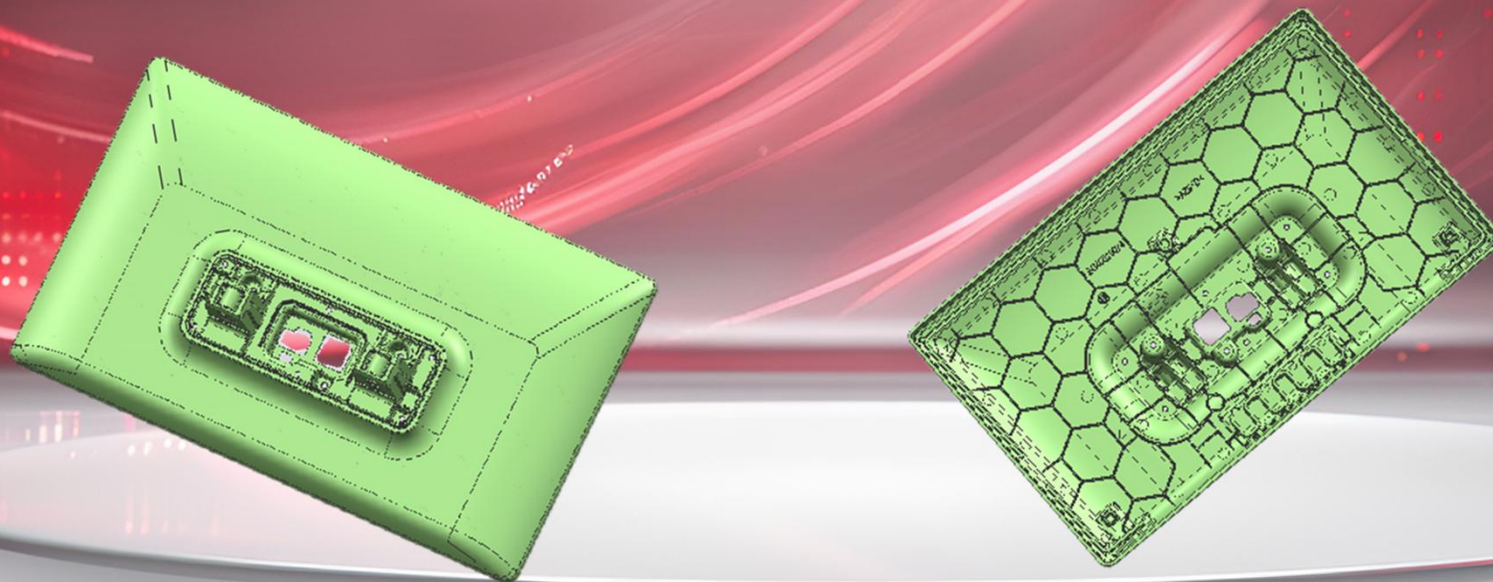

▮ Magnesium-Cast light

SINYUANZM  
星源卓镁

## IP Bracket

Material: AZ91D

Part length: 340mm

Screen size: 15.4-inch

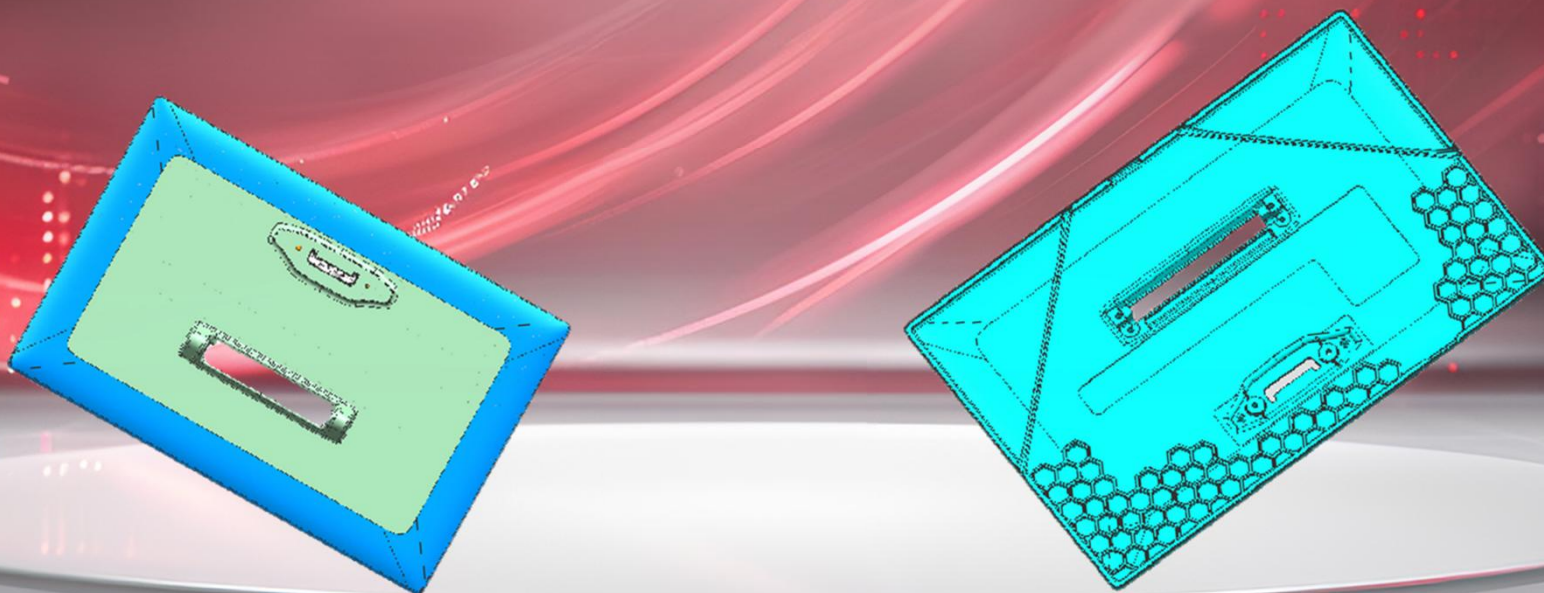

▮ Magnesium-Cast light

SINYUANZM  
星源卓镁

## Dual Display Screen

Material: AZ91D

Part length: 1,500mm

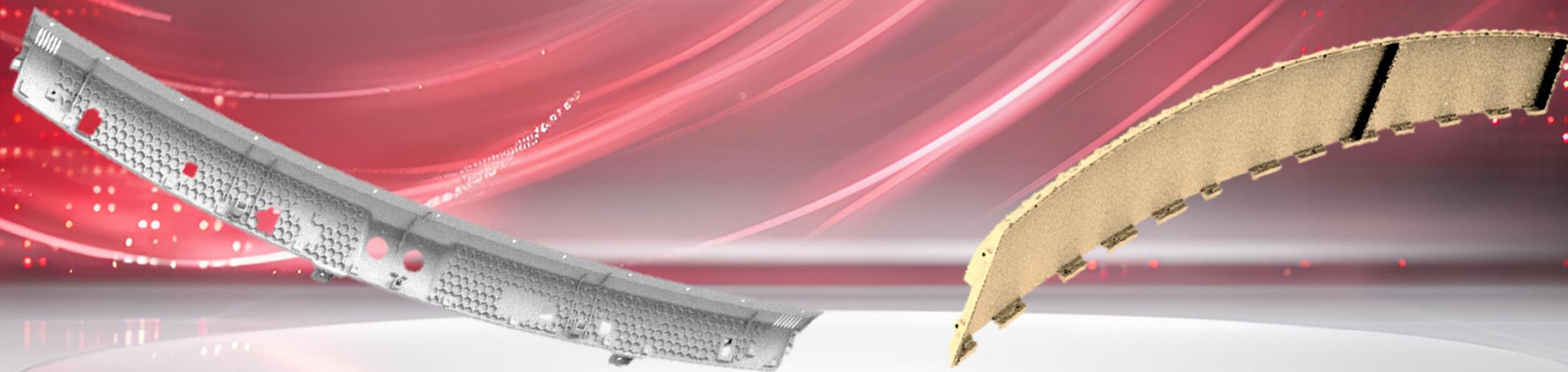

▮ Magnesium-Cast light

SINYUANZM  
星源卓镁

## Dual Display Screen

Material: AZ91D

Part length: 1,200mm



▮ Magnesium-Cast light

SINYUANZM  
星源卓镁

# EV Motor Housing

Material: AZ91D

## Mass production application

智己 IM: L7/LS7/LS6/L6

飞凡 Rising: R7/F7

名爵 MG: Cyberster

First mass production SOP: December 2021

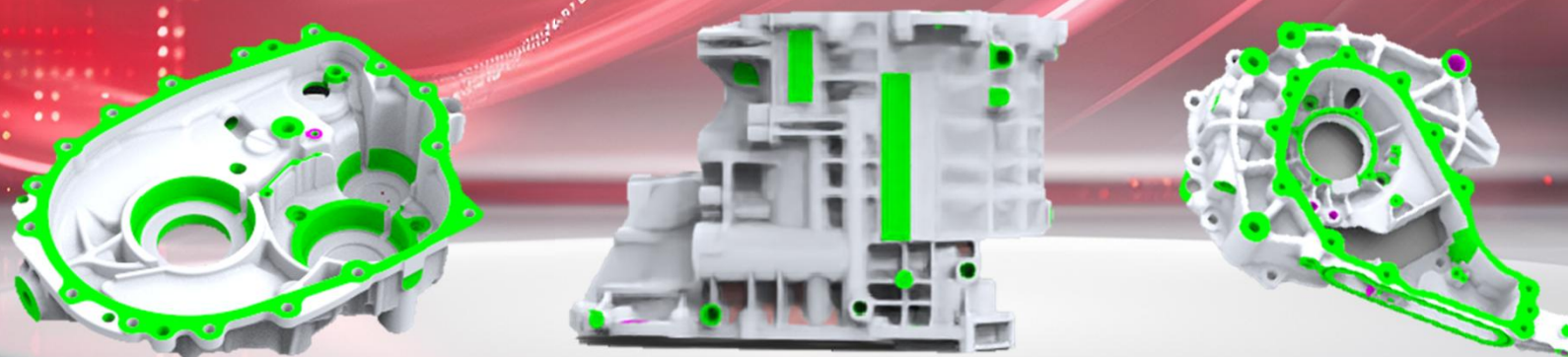

▮ Magnesium-Cast light

SINYUANZM  
星源卓镁

# EV Motor Housing

Material: AZ91D

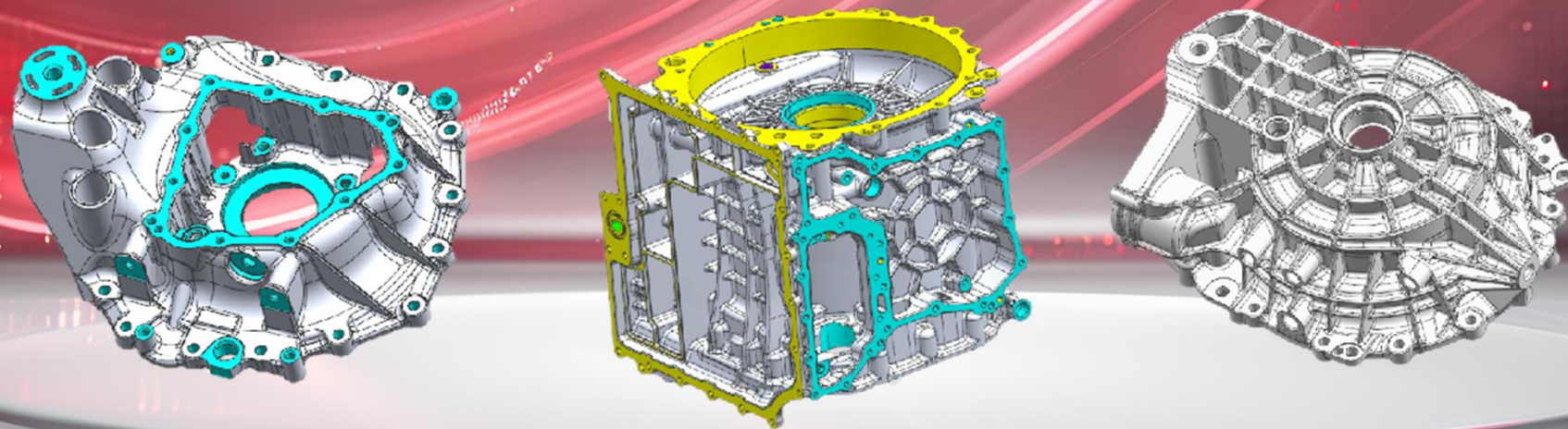

▮ Magnesium-Cast light

SINYUANZM  
星源卓镁

# MPV Door Plank

Material: AM60B

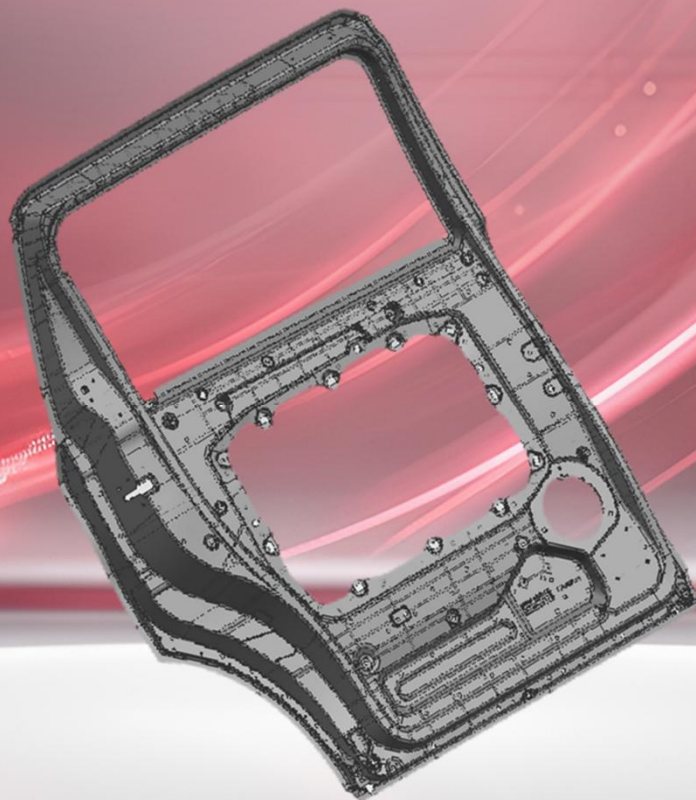

▮ Magnesium-Cast light

SINYUANZM  
星源卓镁

# HUD Housing

Material: AZ91D

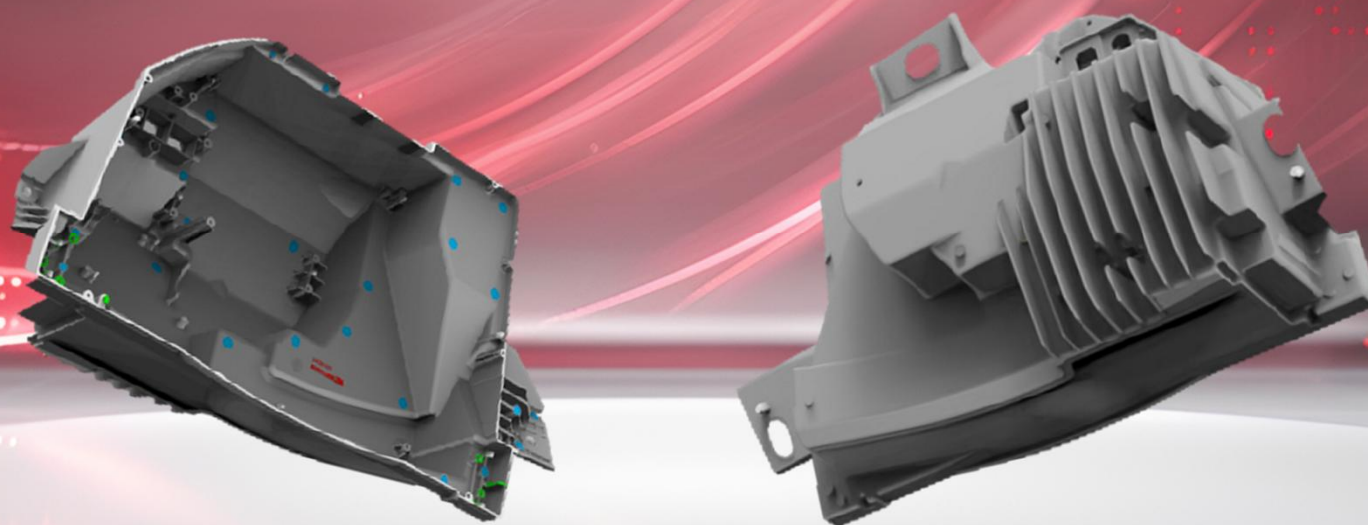

▮ Magnesium-Cast light

SINYUANZM  
星源卓镁

# Console

Material: AM60B

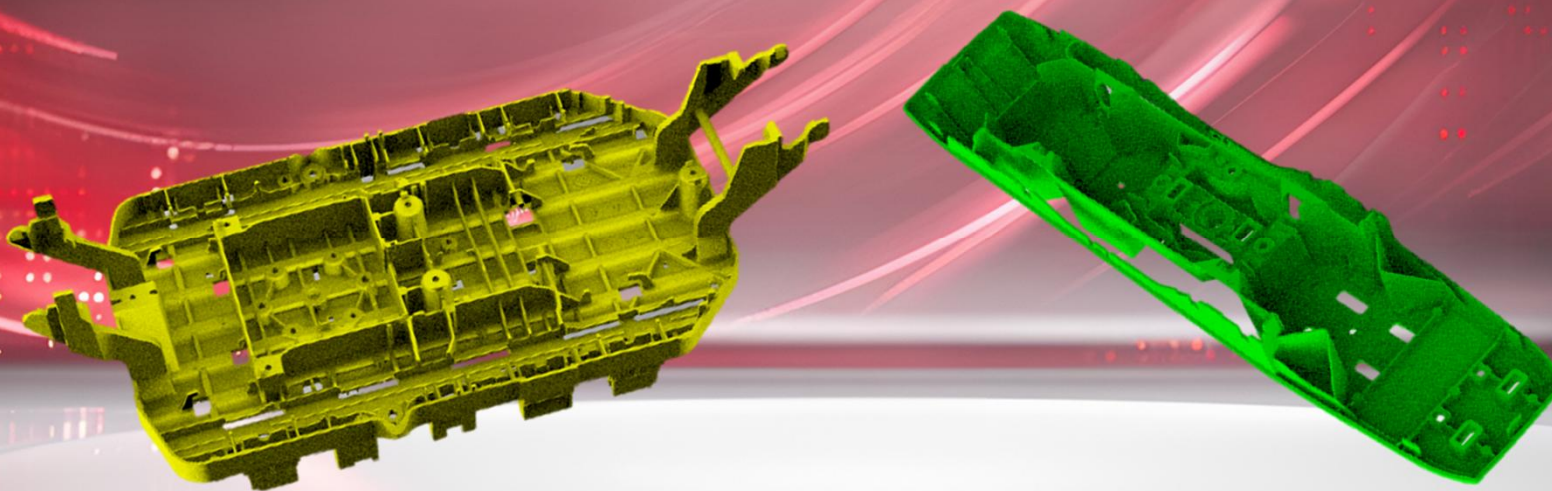

▮ Magnesium-Cast light

SINYUANZM  
星源卓镁

# Console

Material: AM60B

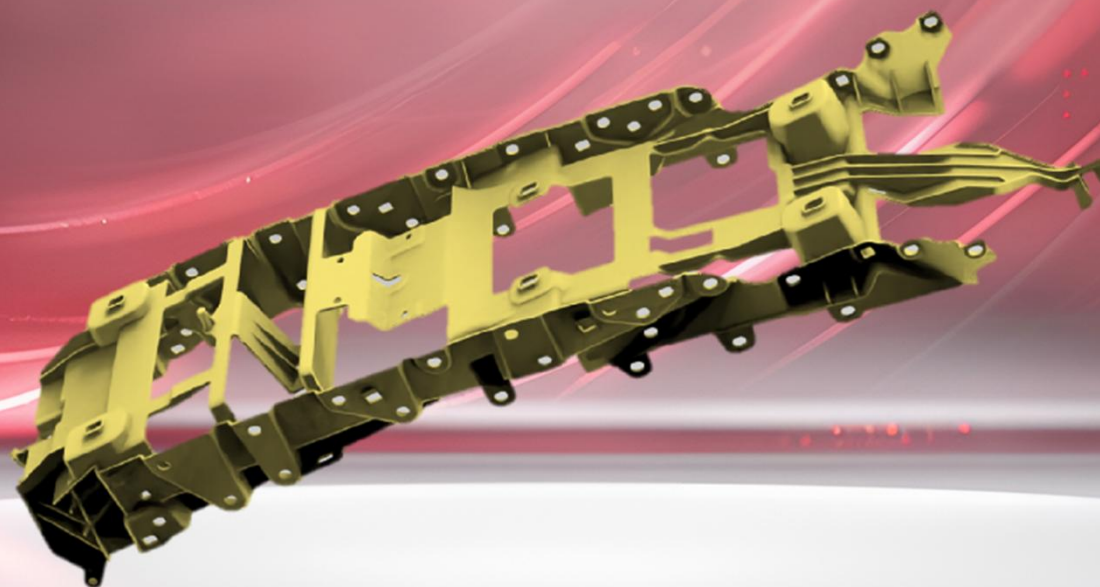

▮ Magnesium-Cast light

SINYUAN ZM  
星源卓镁

# Console

Material: AM50A

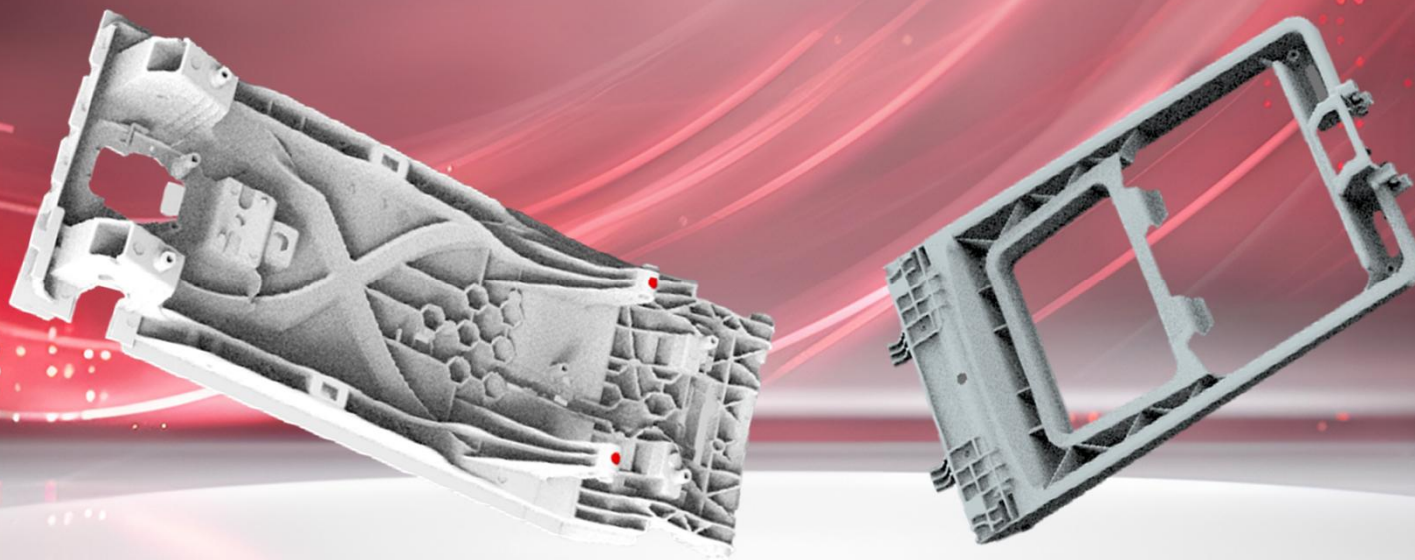

**SINYUAN ZM**  
星源卓镁

# Magnesium-Cast light

NINGBO SINYUAN ZM TECHNOLOGY Co., Ltd.

Stock code: 301398

# 商流

寧波星源卓镁技術股份有限公司製品のご購入に際して、商流をふたつ用意しています。

1. 寧波星源卓镁技術股份有限公司が直接販売
2. 寧波江東夢海進出口有限公司から販売

いずれにおいても日常のお客様フォローは寧波江東夢海進出口有限公司にて行わせていただきます。

寧波江東夢海進出口有限公司 埼玉出張所 [info@menghai.com](mailto:info@menghai.com)